

Gas-Fired Tempered Make-Up Air Unit / EVAP

Model:

TK4-EVAP-1PH-FF

1-Phase, 208V, 5.00 HP, Belt driven with Motorized Damper and 20" Blower. MAX 9600 CFM's

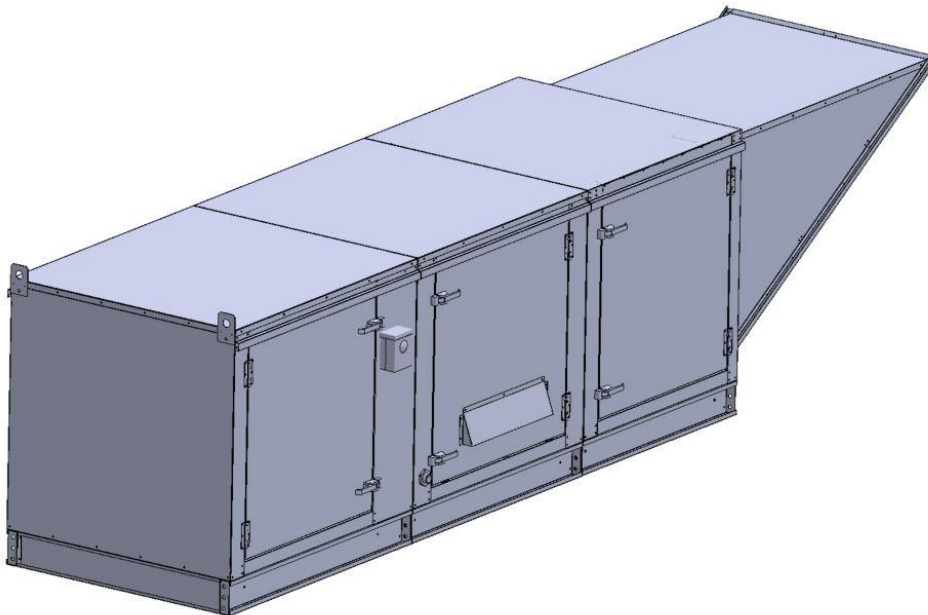



TK4-1000 Direct Fired EVAP (2075 lbs.)

Supply Motor:

Model DTP0054, 5.000 HP, 3 Phase, 208 V, 60Hz, 26.0 FLA, ODP, Premium (E-Plus3) Eff.

Supply Motor Pulleys:

Part Type	Qty	Browning #	Turns Out
Blower Pulley	1	2BK90H	
Motor Pulley	1	2VP42 x 1 1/8	3.5

Burner:

Min Output BTU: 36,667 BTU/Hr
Max Output BTU: 1,100,001 BTU/Hr
Size: 24" long
Gas Type: Natural

Supply Performance:

Volume: 9600 cfm Volume Range: 6000-9600 cfm
RPM 684
TS: 3581 ft/min
SP: 1.060" w.g.
0.500" Ext. + 0.520" Int. + 0.040" Opt.
BHP: 4.695

Heating Schedule:

Altitude: 0'
Winter Entering Air Dry Bulb Temp: 0°F
Temp Rise: 100°F
Output BTU: 1036800
Input BTU: 1126957
BTUs BASED OFF STANDARD AIR DENSITY

Cooling Schedule:

Intake Entering Dry Bulb Temperature: 90°F
Intake Entering Wet Bulb Temperature: 70°F
Intake Entering Relative Humidity: 37%
Intake Leaving Dry Bulb Temperature: 73°F
Intake Leaving Wet Bulb Temperature: 70°F
Temperature drop calculations are based on tested data.

Supply Installation Information:

Gas Inlet Pressure: 7 in. w.c. - 14 in. w.c.
Insurance: No Insurance Requirement (ANSI)
Unit Main Input: 42.5 Amps MCA, 70 Amps MOP, 208 V, 8 AWG Wire Min.
Supply Unit Voltage: 1 phs 208 V 60Hz via VFD

Construction Features

Housing constructed of heavy duty G90 galvanized steel • Forward curved centrifugal blower wheel • Vibration isolation • Adjustable drive assemblies • Adjustable motor mount • Ball bearing motors • Heavy duty, pre-lubricated bearings rated for 200,000 hours of operation • Static resistant belts • Service doors on both sides • Horizontal & down discharge • Large intake area ensures low pressure drop across unit • Spring loaded profile plates automatically adjust for any airflow - no manual setting required! • Weatherproof safety disconnect switch • Modular design provides design flexibility • Fully insulated casing

Blower:

20" forward curved, centrifugal blower. Permanently lubricated pillow-block ball bearings. Enamel finish. 5000-18000 CFM. 1-7/16" x 37.25" Shaft. 1100 max. RPM. Heavy duty angle iron frame. Used in heated and non-heated supply fans.

Temp Control:

RTC Solutions • 40-90°F Discharge Temp Control • Field Wired On/Off Start Command

Intake:

Size # 5 Celdek Evaporative Cooler for Size # 4 Modular Heater. 59.563" Wide x 105.238" Long x 58.375" High. Includes intake hood with filters. For outdoor installation. Use with water softener recommended.

Filters:

8x MV EZ Kleen Metal Mesh Filter. 20"x 25"x 2" Used for heater and supply fan intakes. (3416)

Selected Options:

- Motorized Back Draft Damper 34" X 36" for Size 4 Standard & Modular Heater Units w/Extended Shaft, Standard Galvanized Construction, 3/4" Rear Flange, Low Leakage, NFBUP-S Actuator Included
- Low Fire Start. Allows the burner circuit to energize when the modulation control is in a low fire position.
- Gas Pressure Gauge, 0-35", 2.5" Diameter, 1/4" Thread Size
- Gas Pressure Gauge, -5 to +15 Inches Wc., 2.5" Diameter, 1/4" Thread Size
- Freeze Protection Drain Control kit for Evaporative Coolers. Includes 3-Way water solenoid valve 8316G064 (shipped loose), Pressure switch installed upstream of 2way solenoid in unit, Brass Tee, 2 NPT half inch nipples, and two stage thermostat T678A1361. Field wiring required by others for 3-way valve. For both Celdek and Standard V-bank type Configurations.
- VAV (Variable-Air-Volume) Wiring Package for Commercial Fans. Manual Speed Control Variable Frequency Drive Included
- Supply Variable Frequency Drive - 10 HP Max., 200/240 V, Three Phase, 29.0 A Max., NEMA 1 Enclosure, (Default Shipped Loose for Field Installation) PART NEEDS PROGRAMMING
- VFD factory mounted and wired on unit control panel.

TK4 DIRECT FIRED HEATER WITH EVAP

1. DIRECT GAS FIRED HEATED MAKE UP AIR UNIT WITH 20" BLOWER AND 24" BURNER.
2. EVAP COOLER (LPD CELDEK) - W/INTAKE HOOD W/EZ FILTERS
3. DOWN DISCHARGE - AIR FLOW RIGHT -> LEFT
4. MOTORIZED BACK DRAFT DAMPER 34" X 36" FOR SIZE 4 STANDARD & MODULAR HEATER UNITS W/EXTENDED SHAFT. STANDARD GALVANIZED CONSTRUCTION, 3/4" REAR FLANGE, NFBUP-S ACTUATOR INCLUDED
5. LOW FIRE START. ALLOWS THE BURNER CIRCUIT TO ENERGIZE WHEN THE MODULATION CONTROL IS IN A LOW FIRE POSITION.
6. GAS PRESSURE GAUGE, 0-35", 2.5" DIAMETER, 1/4" THREAD SIZE
7. GAS PRESSURE GAUGE, -5 TO +15 INCHES WC., 2.5" DIAMETER, 1/4" THREAD SIZE
8. FREEZE PROTECTION DRAIN CONTROL KIT FOR EVAPORATIVE COOLERS. INCLUDES 3-WAY WATER SOLENOID VALVE 8316G064 (SHIPPED LOOSE), PRESSURE SWITCH INSTALLED UPSTREAM OF 2WAY SOLENOID IN UNIT. BRASS TEE, 2 NPT HALF INCH NIPPLES, AND TWO STAGE THERMOSTAT T678A1361. FIELD WIRING REQUIRED BY OTHERS FOR 3-WAY VALVE. FOR BOTH CELDEK AND STANDARD V-BANK TYPE CONFIGURATIONS.

NOTE: SUPPLY DUCT MUST BE INSTALLED TO MEET SMACNA STANDARDS. A MINIMUM STRAIGHT DUCT LENGTH EQUAL TO THREE TIMES THE SUPPLY DUCT EQUIVALENT DIAMETER MUST BE MAINTAINED DOWNSTREAM OF UNIT DISCHARGE UNLESS OTHERWISE SPECIFIED. DO NOT RELY ON UNIT TO SUPPORT DUCT IN ANY WAY.

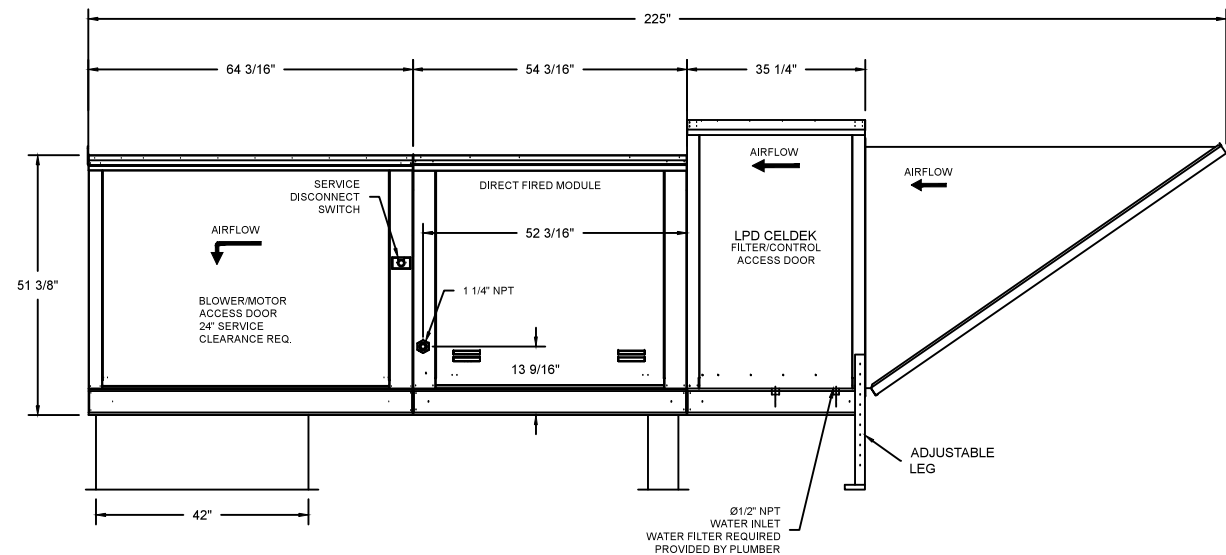
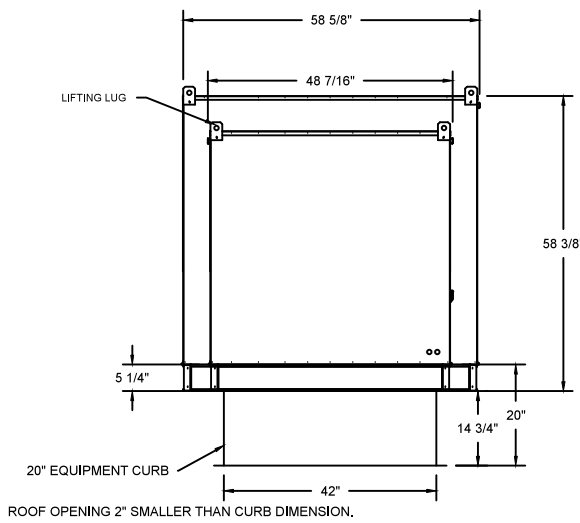
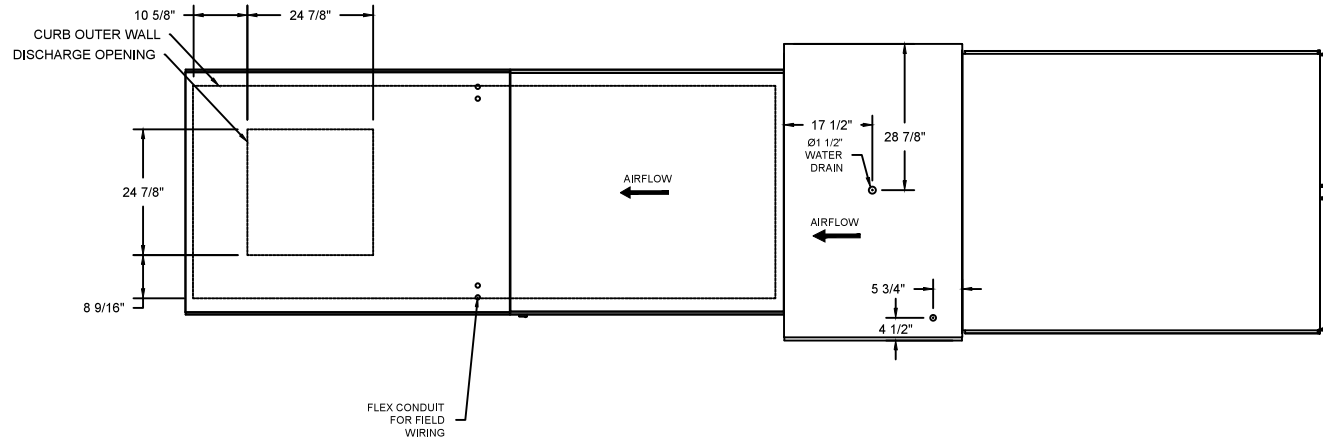

JOB	
LOCATION	
DATE 08/01/2018	JOB #
DWG #	DRAWN BY
REV.	SCALE

(EVAP 9600 5HP/1PH-208V) - HEATER PERFORMANCE CURVES.

9600 CFM, 1.06 SP @ 684 RPM and 4.695 BHP at 0 feet and 100 deg F
 * Please note that these curves were adjusted for job specific temperature and altitude.

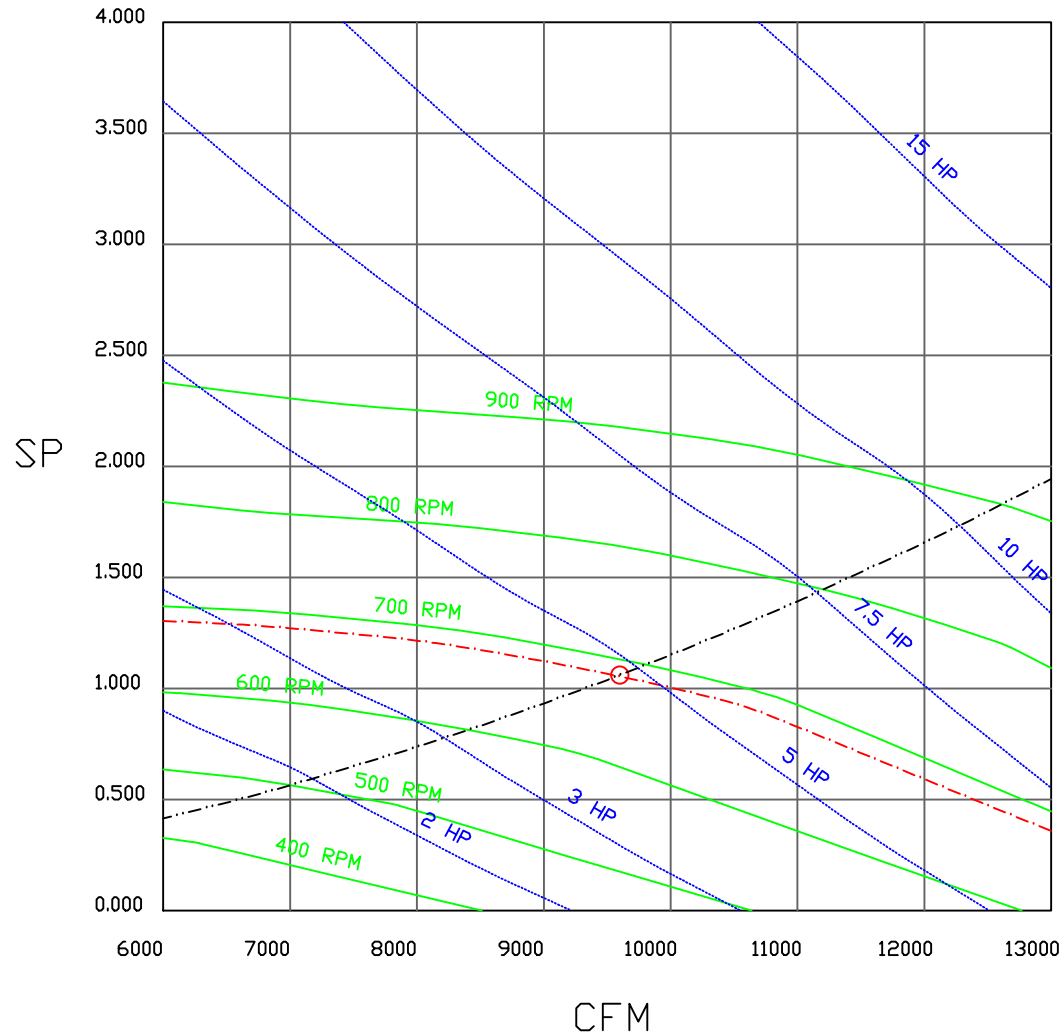

		JOB	
		LOCATION	
		DATE 8/3/2018	JOB #
		DWG #	DRAWN BY
		REV.	SCALE 3/8" = 1'-0"

Direct Fired Heater Wiring

JOB NAKS Direct Fired MUA EVAP

DRAWING NUMBER

SHIP DATE

MODEL TK 1-5 Series

ATTENTION ELECTRICIAN!
 DRIP FOR DISCONNECT CONNECTION
 IS FACTORY SUPPLIED
 CONNECT POWER TO THE DRIP

Installed Options
 Field Wired Single Switch Control
 Motorized Back Draft Damper

Discharge Temp. Control

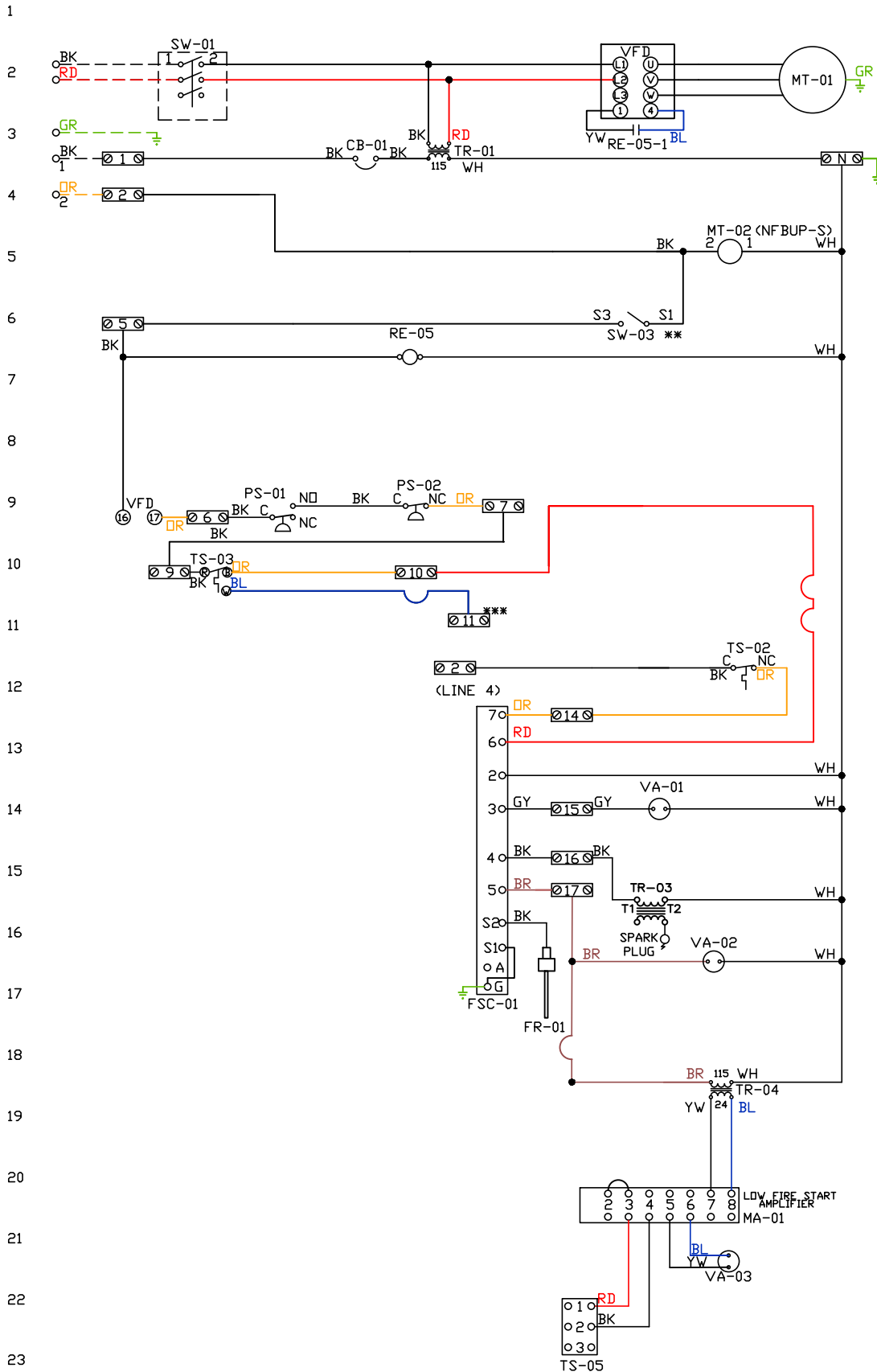

Label	Description	Location
CB-01	Circuit breaker (2amp)	[3]
FR-01	Flame rod	[16]
FSC-01	Fireeye FSC	[11-14]
MA-01	Modulating amplifier	[19]
MT-01	Supply motor	[2]
MT-02	Damper motor	[5]
PS-01	Low Airflow Switch	[9]
PS-02	High Airflow Switch	[9]
RE-05	VFD Start Relay	[3I6]
SW-01	Main disconnect switch	[2]
SW-03	Damper end limit switch	[4]
TR-01	Power transformer(200v/33)	
TR-03	Ignition transformer	[14]
TR-04	Power transformer(20va)	[17]
TS-02	High temp limit switch	[10]
TS-03	Intake Air Sensor	[10]
TS-05	Discharge Air Sensor	[21]
VA-01	Pilot gas valve	[12]
VA-02	Main gas valve	[15]
VA-03	Modulating gas valve	[20]

MOTOR INFO
 SUPPLY 5HP-208V-3P-26.0FLA
 VFD PART: ESV752N02TXB

ELECTRICAL INFORMATION
 MOTOR/CTRL CIRCUIT MCA: 42.5A
 MOTOR/CTRL CIRCUIT MOP: 70A

NOTES
 --- DENOTES FIELD WIRING
 ——— DENOTES INTERNAL WIRING

** TERMINALS S4 AND S6 USED ON NF & AF SERIES ACTUATORS
 *** TERMINAL 11 PROVIDES COOLING CONNECTION

WIRE COLOR	SOCKET STYLE
BK-BLACK	ND 4 3
BL-BLUE	NC 2 1
BR - BROWN	CDL 8 7
DR - ORANGE	CDM 6 5
GY - GRAY	
GR - GREEN	
WH - WHITE	
PR - PURPLE	
RD - RED	
YW - YELLOW	

Installed Options

Component Identification

Label	Description	Location
SW-01	Thermostat	[2]
SW-02	Overflow Switch	[6]
SW-03	Pressure Switch	[3]
TI-01	Spray Timer	[5-7]
VA-01	Internal Solenoid Valve	[5]
VA-02	3-Way Solenoid Valve	[7]

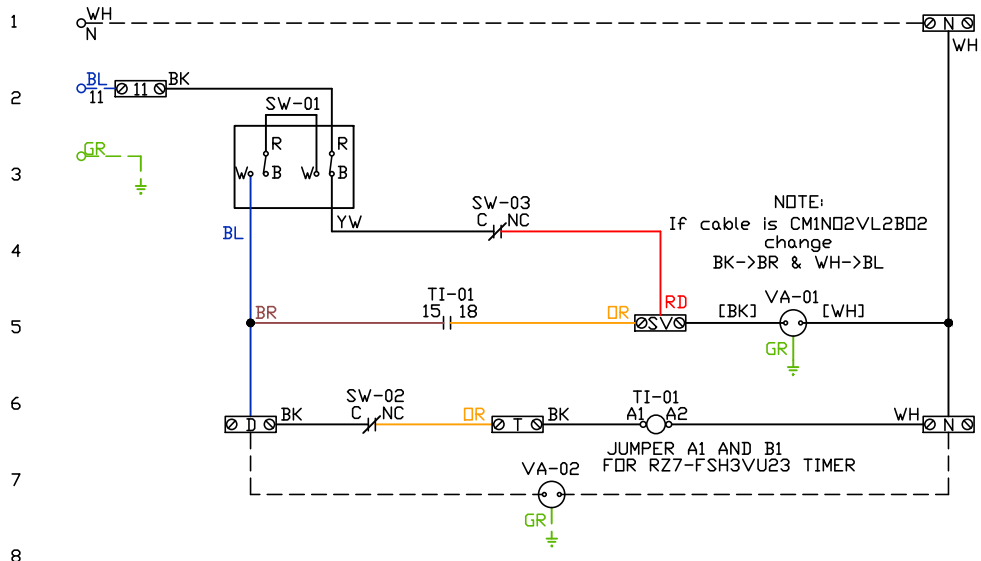

POINT-TO-POINT SUMMARY OF DRAIN CONNECTION

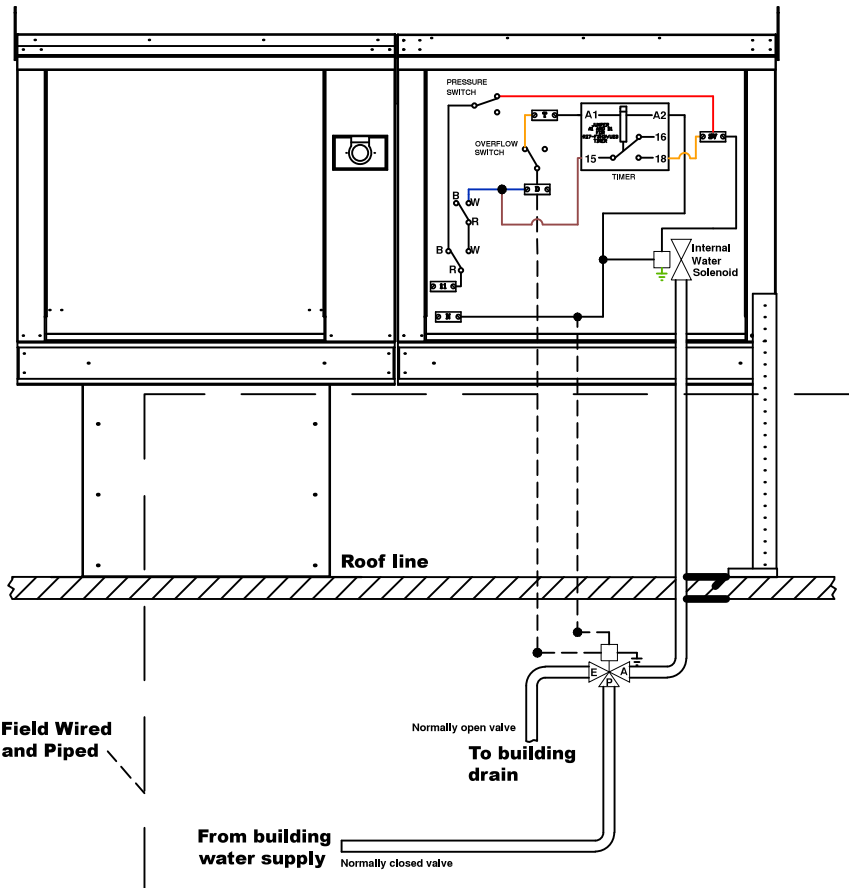

NOTES

- DENOTES FIELD WIRING
- DENOTES INTERNAL WIRING

WIRE COLOR

- BK - BLACK
- BL - BLUE
- BR - BROWN
- DR - ORANGE
- RD - RED
- WH - WHITE
- YW - YELLOW
- GR - GREEN
- GY - GRAY
- PR - PURPLE
- PK - PINK

VFD Wiring

JOB NAKS DIRECT FIRED MUA EVAP

DRAWING NUMBER

SHIP DATE

MODEL TK 1-5 Series

Installed Options
Manual Control

SMV SERIES VARIABLE FREQUENCY DRIVE

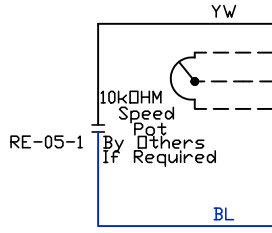

TERMINAL	FUNCTION
1	Digital Input(Start/Stop)
2	Analog Common
5	Analog Input: 0-10 VDC
6	Internal DC Supply for Speed Pot: +10 VDC
25	Analog Input: 4-20 mA
30	Analog Output
4	Digital Reference/Common
11	Internal DC Supply for External Devices
13A	Digital Input: Configurable with P121
13B	Digital Input: Configurable with P122
13C	Digital Input: Configurable with P123
14	Digital Output: Configurable with P142
30	Analog Output: Configurable with P150...P155
16	Relay Output: Configurable with P140
17	
PE	Ground Terminal
L1	3 Phase Input or Single Phase Input
L2	3 Phase Input or Single Phase Input
L3 (N)	3 Phase input (Neutral for 120v)
U	3 Phase AC Motor
V	3 Phase AC Motor
W	3 Phase AC Motor

BK
OR BURNER CIRCUIT CONTACT

POWER SUPPLY

MOTOR

Component Identification

RE-05 VFD Start relay [2]

SUPPLY DRIVE PARAMETER SETTINGS*

All external control wires to motor speed control should be 16-20 AWG shielded multiconductor cables and must not be run in the same conduit or raceway with any high power wiring. Ground Shielded Cable at the drive chassis ONLY.

PG. 11 OF THE DRIVE MANUAL DESCRIBES THE PROPER INSTALLATION PROCEDURE

PG. 19 OF THE DRIVE MANUAL DESCRIBES THE PROGRAMMING PROCEDURE OF THE DRIVE

PG. 23 OF THE DRIVE MANUAL DESCRIBES THE PARAMETER SETTINGS OF THE DRIVE

*NOTE: THE DEFAULT PASSWORD FROM THE FACTORY REQUIRED TO PROGRAM THE DRIVE IS '225'.

EPM PROGRAM: VAV_MANKUSE LG_HP EPM IF >= 15HP)
 P100 (Start Source) = 01 (Terminal Strip)
 P102 = ***Minimum Frequency (Hz)
 P103 = ***Maximum Frequency (Hz)
 (P103 is based on max wheel RPM)
 P110 (Start Method) = 03 (Auto Re-start)
 P140 (Form A [NO] Relay) = 01 (Run)
 P144 (Relay Inversion) = 00 (None)
 P166 (Carrier Frequency) = 00 (4 kHz)
 P171 (Current Limit) = 150 (% of Max I)

Adjust manually on all drives
 P107 = 00 (If 120 or 208 VAC)
 or 01 (If 230, 480 or 575 VAC)
 P108 - Motor FLA x 100 / Drive Output Rating
 P165 (Base Voltage) = Set to Motor Voltage
 (Preset@230V) P165 FDR STANDARD DRIVE ONLY
 P167 (Base Frequency) = Calculated Per Fan

When Speed POT is Required the Following Parameters Must be Set:

P101 (Reference Source) = 01 (0-10 VDC)
 P160 (Speed @ 0 VDC Signal) = Min Frequency
 P161 (Speed @ 10 VDC Signal) = Max Frequency

IT MAY BE REQUIRED TO FULLY POWER DOWN THE DRIVE AND TURN BACK ON IN ORDER TO INITIATE NEW PARAMETER SETTINGS.

***Min. and Max. Frequency Settings override all other Preset speeds/Parameters.

MOTOR INFO
 SUPPLY 5HP-208V-3P-26.0FLA
 VFD PART: ESV752N02TXB

ELECTRICAL INFORMATION
 MOTOR/CTRL CIRCUIT MCA: 42.5A
 MOTOR/CTRL CIRCUIT MDP: 70A

NOTES

----- DENOTES FIELD WIRING
 _____ DENOTES INTERNAL WIRING

WIRE COLOR

BK - BLACK YW - YELLOW
 BL - BLUE GR - GREEN
 BR - BROWN GY - GRAY
 OR - ORANGE PR - PURPLE
 RD - RED PK - PINK
 WH - WHITE

GENERAL NOTES